

3528 SMD Chip LED - Orange multicomp^{PRO}

**RoHS
Compliant**



Features

- 3.5mm × 2.8mm SMT LED, 1.9mm Thickness.
- Wide Viewing Angle.
- Ideal For Backlight And Indicator.

Applications

- Automotive: Backlighting in dashboard and switch.
- Telecommunication: Indicator and Backlighting in telephone and fax.
- Flat Backlight for LCD switch and symbol.

Package Dimensions

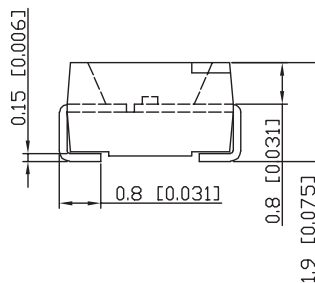
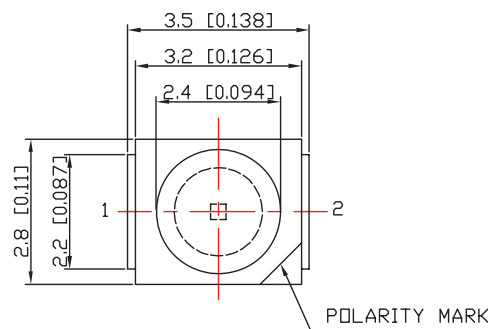

Dimensions : Millimetres

Notes

1. All dimensions are in millimeters.
2. Tolerance is ± 0.25 unless otherwise noted.
3. Specifications are subject to change without notice.

Device Selection Guide

Part No.	Chip		Lens Colour
	Material	Emitted Colour	
MP007082	(InGaAlP)	Orange	Water Clear

3528 SMD Chip LED - Orange **multicomp**PRO

Absolute Maximum Ratings at TA=25°C

Parameter	Symbol	Value	Unit
Power Dissipation	P _D	62	mW
Forward Current	I _F	25	mA
Peak Forward Current*1	I _{FP}	100	mA
Reverse Voltage	V _R	5	V
Operating Temperature	T _{opr}	-40°C To +85°C	
Storage Temperature	T _{stg}	-40°C To +85°C	

Notes:

*1: Pulse width≤0.1ms, Duty cycle≤1/10

Electrical / Optical Characteristics at TA=25°C

Parameter	Symbol	Min.	Typ.	Max	Unit	Test Conditions
Forward Voltage	V _F	1.8	—	2.6	V	I _F =20mA
Reverse Current	I _R	—	—	10	μA	V _R =5V
Dominant Wavelength	λ _D	601	—	613	nm	I _F =20mA
Luminous Intensity	I _v	500	—	1400	mcd	I _F =20mA
Viewing Angle	2θ _{1/2}	—	120	—	Deg.	I _F =20mA

Remarks:

If special sorting is required (e.g. binning based on forward voltage, luminous intensity, or chromaticity), the typical accuracy of the sorting process is as follows:

1. wavelength: ±1nm
2. Luminous Intensity: ±15%
3. Forward Voltage: ±0.1V

3528 SMD Chip LED - Orange multicomp^{PRO}

Typical Electrical/Optical Characteristics Curves

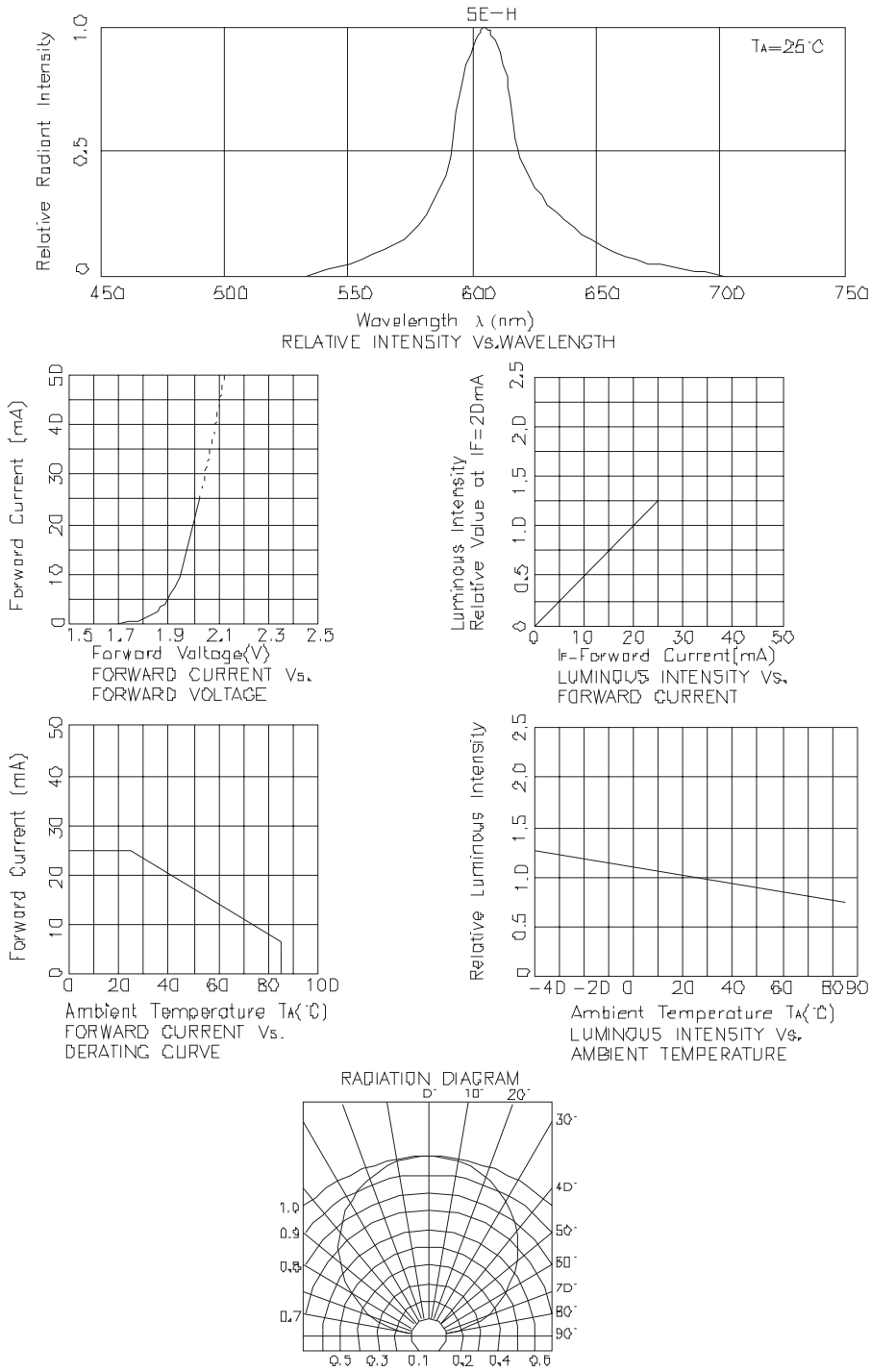

Dimensions : Millimetres

Newark.com/multicomp-pro
 Farnell.com/multicomp-pro
 Element14.com/multicomp-pro

multicomp^{PRO}

3528 SMD Chip LED - Orange **multicomp** PRO

Soldering Profile

Reflow Soldering Profile For Lead-free SMT Process.

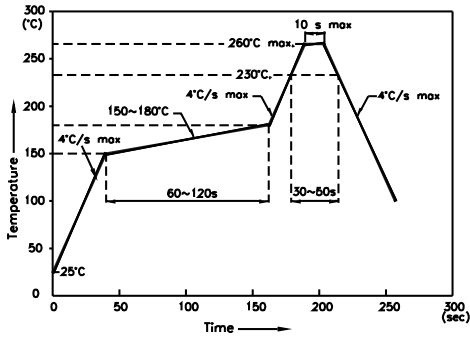

Notes

1. We recommend the reflow temperature 245°C. ($\pm 5^\circ\text{C}$) The maximum soldering temperature should be limited to 260°C.
2. Don't cause stress to epoxy resin while it is exposed to high temperature.
3. Number of reflow process shall be 2 times or less.

Recommended soldering pattern

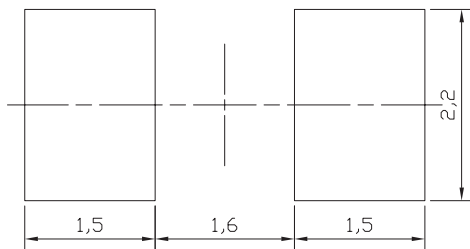

Tape specifications

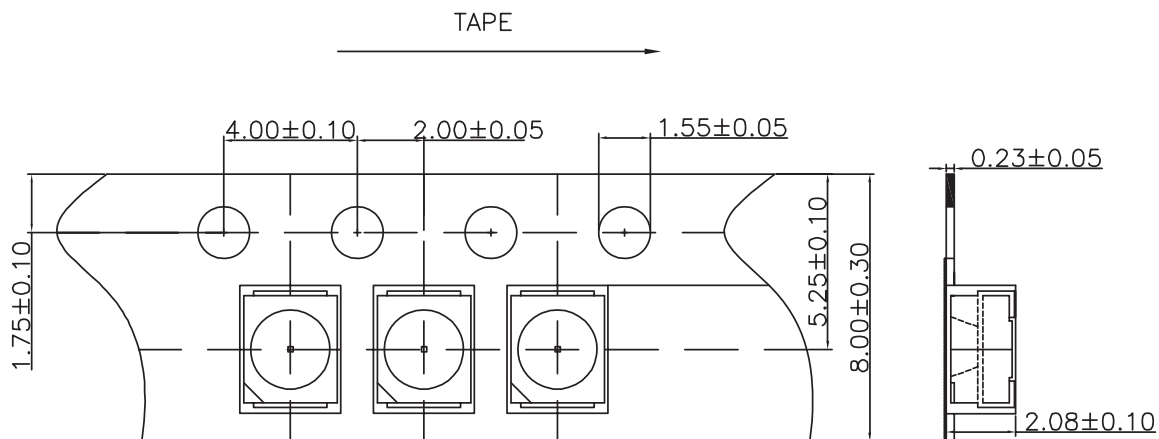

Dimensions : Millimetres

Newark.com/multicomp-pro
 Farnell.com/multicomp-pro
 Element14.com/multicomp-pro

multicomp PRO

3528 SMD Chip LED - Orange **multicomp**PRO

Storage

- Storage condition before opening the package: 5°C to 30°C, the largest percentage relative humidity is 60% and the storage period is one month. The LEDs beyond the storage period just can be used after dealing as step 4.
- After opening the package, If the LEDs will be Infrared reflow soldering, Oxygen phase reflow soldering or any other welding.
 - a. must be welding within 24 hours.
 - b. the storage humidity must be below 30% .
- If the situation does not satisfy 2a or 2b, the LEDs must be roasted.
- If the LEDs need to be roasted, the roast temperature should be 60°C+/-3 and the roast timeshould be 48 hours.

ESD (Electrostatic Discharge)

Static Electricity or power surge will damage the LED.

The following procedures may decrease the possibility of ESD damage.

- All production machinery and test instruments must be electrically grounded.
- Use a conductive wrist band or anti-electrostatic glove when handling these LEDs.
- Maintain a humidity level of 50% or higher in production areas.
- Use anti-static packaging for transport and storage.

Cleaning

- Led should be cleaned in a normal temperature and the time for cleaning should be less than 3 minutes; please use Alcohol as cleaner ,before you use other cleaning solvent ,please make sure that the cleaner will not make any damage to the LED performance or the appearance .
- Ultrasonic Cleaning is also commonly used for cleaning LED , please verify the Ultrasonic cleaning's Power and time to avoid any damage to the LED.

Part Number Table

Description	Part Number
SMD LED, Orange, 120°, 1400mcd, 3.5mm x 2.8mm	MP007082

Important Notice : This data sheet and its contents (the "Information") belong to the members of the AVNET group of companies (the "Group") or are licensed to it. No licence is granted for the use of it other than for information purposes in connection with the products to which it relates. No licence of any intellectual property rights is granted. The Information is subject to change without notice and replaces all data sheets previously supplied. The Information supplied is believed to be accurate but the Group assumes no responsibility for its accuracy or completeness, any error in or omission from it or for any use made of it. Users of this data sheet should check for themselves the Information and the suitability of the products for their purpose and not make any assumptions based on information included or omitted. Liability for loss or damage resulting from any reliance on the Information or use of it (including liability resulting from negligence or where the Group was aware of the possibility of such loss or damage arising) is excluded. This will not operate to limit or restrict the Group's liability for death or personal injury resulting from its negligence. Multicomp Pro is the registered trademark of Premier Farnell Limited 2019.

Newark.com/multicomp-pro
Farnell.com/multicomp-pro
Element14.com/multicomp-pro

multicompPRO